

viccarbe

Fuste

Designed by Victor Carrasco

Technical info - EN

HEIGHT 65 | HEIGHT 25½"

FUS210ROH-
table 210x160 cm | 82.7x63"

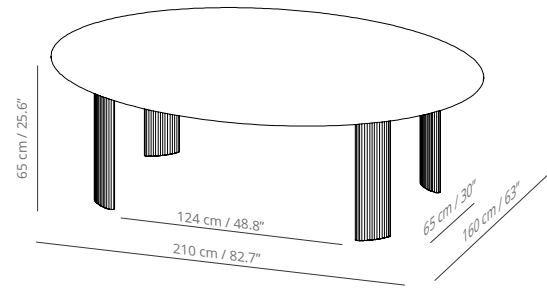

FUS260ROH-
table 260x180 cm | 102.4x70.9"

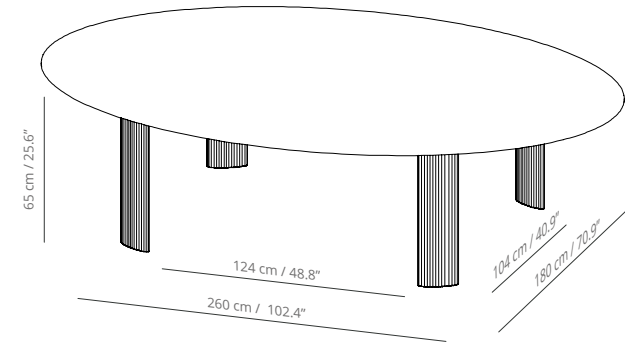

FUS240ROH-
table 240x120 cm | 94.5x47.2"

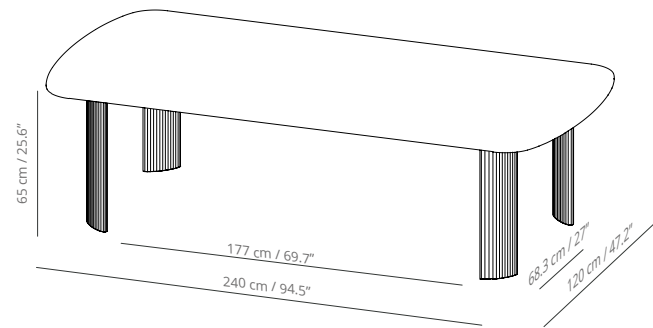

HEIGHT 74 | HEIGHT 29½"

FUS210RO-
table 210x160 cm | 82.7x63"

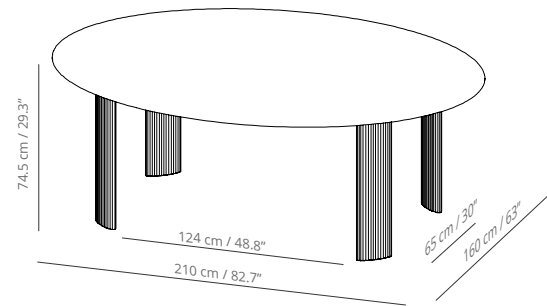

FUS260RO-
table 260x180 cm | 102.4x70.9"

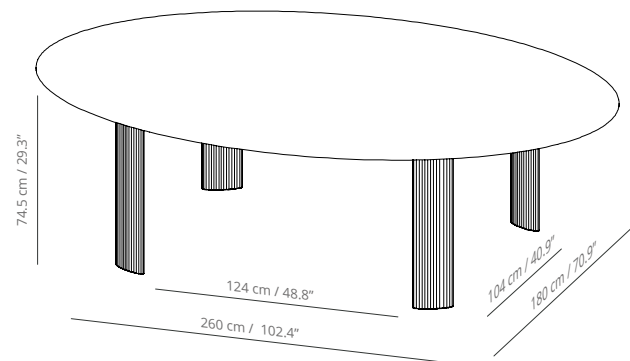

FUS240RO-
table 240x120 cm | 94.5x47.2"

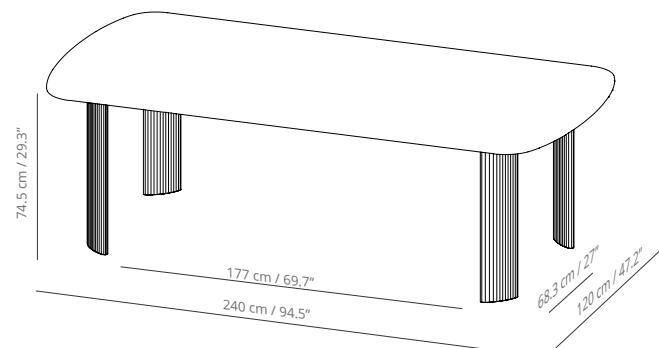

SEATING CAPACITY

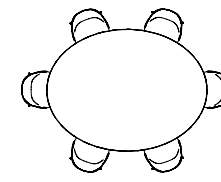

Up to 6
210x160 cm | 82.7x63"

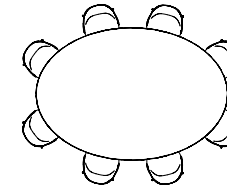

Up to 8
260x180 cm | 102.4x70.9"

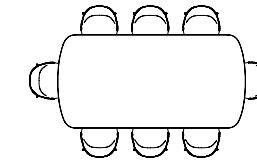

Up to 8
240x120 cm | 94.5x47.2"

**Seats calculated using Aleta chair, might differ when choosing other models*

LEG OPTIONS

LEGS POSITIONS

Legs can go in two positions, sitting up to 10 guests.

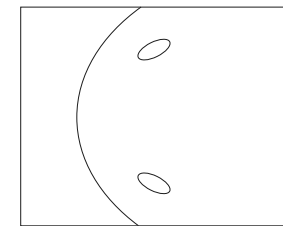

Positon A

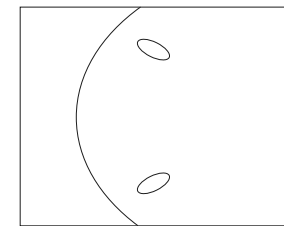

Positon B



Stained solid wood - Wire management.
Management leg with a registered system to conduct wires from the top of the table to the floor completely hidden. Made of solid oak, stained in the same finish as the table. The code of the leg must be noted in the order (FUSPR).



**Patent pending wire management system*



Stained solid wood - solid oak leg stained with the finishes of our collection.

TABLETOP MATERIALS

MDF - STAINED

30 mm MDF board with a natural oak veneer polished in the finishes of our collection.

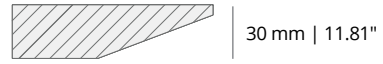

matt stained oak



bleached stained oak



cognac stained oak



ash stained oak

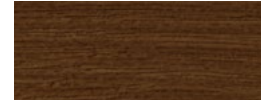

walnut stained oak

ACCESSORIES & ELECTRIFICATIONS



Hidden hatch set. Built-in wooden hatch, with the same material and finish as the table top. Can be opened from both sides. Dimensions: 32x15 cm | 12.59"x5.90"



Hatch with frame. Metallic hatch access to the lower part of the table for wooden table tops. Same finish for frame and hatch, available in black, grey or white. Does not include power options. Dimensions: 32x15 cm | 12.59"x5.90"



Hatch with frame plus. Metallic hatch access to the lower part of the table for wooden table tops. Metal frame available in black or grey and central part in matching veneer. Does not include power options. Dimensions: 32x15 cm | 12.59"x5.90"



Hatch with frame & powerbox. Metallic hatch with 4 sockets or combined with built-in multimedia devices. Metal frame and hatch are available in black or grey. Dimensions: 32x15 cm | 12.59"x5.90"



Hatch with frame plus & powerbox. Metallic hatch with 4 sockets or combined with built-in multimedia devices. Metal frame available in black or grey and central part in matching veneer. Dimensions: 32x15 cm | 12.59"x5.90"



Cut out. Table top custom cut out.

Let's talk

We want to help you find the best designs for your project. Contact us and our team will get back to you as soon as possible.

CONTACT US

viccarbe

Fuste

Designed by Victor Carrasco

Catalogue - EN

V01

2023



Victor Carrasco

Born in Valencia (Spain) in 1974, Victor Carrasco began his professional career after graduating Cum Laude in Industrial Design Engineering at the Polytechnic University of Valencia.

Far from fashions and trends, he develops and puts international brands in the center, with remarkable added value, thanks to his passion for synthesis, sustainable growth and his pragmatic vision of the future.

Founder and Strategic Director at Viccarbe, a role that he combines since 2007, with being one of the counselors of Steelcase, the prestigious American multinational company, he also collaborates with many other renowned brands.

Throughout his career, he has been honored with the most prestigious prizes such as Príncipe Felipe Award for Entrepreneurial Excellence, German Design Award, IF Design Award or the Iconic Awards 2022: Best of Best Innovative Material, among others.

FUSTE

A tribute to classic architecture

Collection designed by Victor Carrasco, 2023



Warm, perfectly balanced, and subtle. Fuste is our tribute to classic architecture. A collection of solid oak tables with organic lines, designed by Victor Carrasco to be the nexus where meetings, gatherings, and celebrations encounter. Its oval-shaped tabletop, with a very light and almost ethereal outline, contrasts with its much more ornamented legs, conveying a special allure to its almost sculptural design.

The table collection takes its name from the indispensable point of union between the column's base and capital, the shaft

- *Fuste* in Spanish -, an unmistakable architectural element since the times of classical Greece. This section is its *raison d'être*, as every column is raised with it and can never be conceived without it. An essential element, materialized in four solid oak legs, that connect and give meaning to the overall table concept.

This interplay between the lightness of its tabletop, and its distinctive four legs, designed with delicate vertical lines, pay tribute to traditional woodworking, carpentry, and the heritage of true craftsmanship. The start of fine design.

"A minimalist piece meticulously crafted in solid oak wood, to transmit warmth, dimension and durability to any atmosphere."





WARM MINIMALISM

Designer Victor Carrasco envisioned the table collection as a further step in his search for balance and warm minimalism. A table of pure organic shapes, designed to suggest but not impose and add value and warmth to all sort of spaces, from domestic to hospitality, from corporate to contract.



Warm minimalism
for flexible work



Fuste table H74cm | 29.13" and Copa chairs

Fuste table H74cm | 29.13" and Aleta chairs





The interplay between the lightness of its tabletop and its delicate solid oak legs pay tribute to traditional woodwork

Fuste comes in five coveted shades, all made in oak wood from controlled cut timber: Matt, Bleached, Cognac, Walnut and Ash. Timeless, neutral and inviting tones to enrich and complement spaces, and offer even more solutions to satisfy every taste and necessity.



Matt



Bleached



Cognac



Walnut



Ash

Multiple shades of wood

ELECTRIFICATIONS

The table can include our patented electrification system, bringing agility to every working or socializing environment. Designed by Viccarbe's engineering team, the cable is hidden through one of the legs, with no visible joints or screws as it works by magnetic attraction. With a simple gesture, users can easily conceal cables, keeping the space clutter-free. On the tabletop, Fuste can include a powerbox that integrates and respects the table's ethereal silhouette. A practical technical solution that does not interfere and brings incalculable added value .



Left, Fuste's patented electrification system |
Right, Fuste with Alea chairs

FUSTE H65 | 25.59" FOR LOUNGE CHAIR SEATING

Let's talk about comfort. Fuste is also available in a lower height of 65cm | 25.59" to match many of the lounge chairs in our collection, promoting comfortable working in offices and residential environments. Ideal when having a simple cup of coffee during a videocall meeting or a light work lunch. It is also a convenient solution for low dining in restaurants seeking a welcoming atmosphere for guests to enjoy the full culinary experience, slowly but surely. With Fuste you sit relaxed, and easy, appreciating the present moment.

Lower height version
for lounge chairs

Fuste H65 | 25.59" with Penta lounge chairs.



Fuste H74 | H29.13"



210x160 cm | 82.67x62.99"

260x180 cm | 102.36x70.86"

Fuste, Lounge chair height H65 | H25.59"



210x160 cm | 82.67x62.99"

260x180 cm | 102.36x70.86"

Leg position

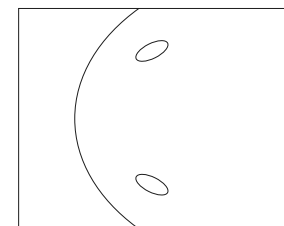

Positon A

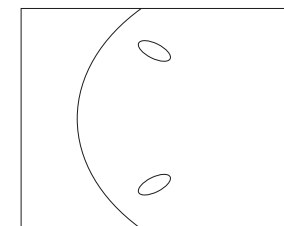

Positon B

Legs can go in two positions, sitting up to 10 guests.

Connectivity



1. Hidden powerbox set
2. Powerbox
3. Patented wire management leg

