

# STOCKHOLM

Mario Ruiz. 2012

## ESPAÑOL

Colección de aparadores, cómodas, muebles de televisión y escritorios ganadores del premio Red Dot 2015 con un singular acabado de aluminio en la parte superior. Los elementos de puertas incluyen estante regulable en altura. Los elementos sin zócalo incluyen pies regulables.

### MATERIALES

- Interior y exterior en tablero de MDF E1 y tablero de partículas E1 (bajo contenido en formaldehído) aplacado en madera de roble o nogal natural con malla continua. Puerta TV calada alistonada en madera maciza.
- Aluminio anodizado o metal liso mate.
- Puertas sin tiradores con apertura a 105°.
- Cajones con guías de extracción total.
- Herrajes marca Salice.
- Zócalos de acero termo-lacado texturizado con pies regulables.

## ENGLISH

Sideboards, drawer units, TV units and desks, winner of the Red Dot 2015 award, with a particular aluminium top finish. Door units include height adjustable shelf.

### MATERIALS

- MDF E1 fibreboard and E1 (low formaldehyde content) particleboard with matching patterned oak or walnut veneer solid wood slatted TV door.
- Anodised aluminium or matt satin lacquered top.
- Doors with no handles opening 105°.
- Drawers with full extraction runners.
- Salice hinges.
- Epoxy powder-coated metal base with adjustable feet.

## FRANÇAIS

Collection de buffets, commodes, meubles de télévision et bureaux lauréats du prix Red Dot 2015 avec une finition spéciale d'aluminium en partie supérieure. Les éléments de porte incluent des étagères réglables en hauteur.

### MATÉRIAUX

- Intérieur et extérieur en panneau MDF E1 et panneau de particules E1 (faible teneur en formaldéhyde) plaqué en chêne ou noyer naturel avec une maille continue. Porte TV ajourée lamelles en bois massif.
- Aluminium anodisé or métal mat.
- Portes sans poignées avec ouverture à 105°.
- Tiroirs avec glissières à extraction totale.
- Ferrures de la marque Salice.
- Socle en acier thermo-laqué texturé avec pieds réglables.

## DEUTSCH

Kollektion von Sideboards, Kommoden, Fernsehmöbel und Schreibtische, die den RED DOT 2015 Preis gewonnen hat, mit einer einzigartigen Endfertigung aus Aluminium im oberen Bereich. Das Möbelmodul mit Tür beinhaltet ein höhenverstellbare Fachboden.

### MATERIALIEN

- Der innere und äußere Bereich des Möbels aus MDF E1 Platten und Spanplatte E1 (niedriger Inhalt vom Formaldehyd) mit Furnier in Eiche oder Nussbaum mit durchlaufendem Furnierbild beschichtet. Durchlässige Tür für elektronische Geräte aus massiven Holzleisten.
- Anodisiertes Aluminium oder Glattes metall.
- Türen ohne Griffe mit einen 105° Öffnungswinkel.
- SchubBoxen mit Vollauszug.
- Beschläge der Marke Salice.
- Stahlsockel mit thermolackierter strukturierter Oberfläche mit höhenverstellbaren Füßen.

## ITALIANO

Collezione di credenze, comò, mobili TV e scrittori vincitori del premio Red Dot 2015 con una particolare finitura di alluminio della parte superiore. Gli elementi delle ante includono scaffali regolabili in altezza

### MATERIALI

- Interno ed esterno in MDF E1 e pannello di particelle E1 (a basso contenuto di formaldeide), impiallacciato con legno di rovere o noce naturale con maglia continua . Anta TV lavorata con listoni di legno massello.
- Alluminio anodizzato o metallo opaco.
- Ante senza maniglie con apertura a 105°.
- Cassetti con guide ad estrazione completa.
- Serrature e cerniere della marca Salice.
- Battiscopa di acciaio termolaccato con texture e piedi regolabili.

STOCKHOLM



STOCKHOLM TECHNIC



STOCKHOLM SLIM



STOCKHOLM CHEST OF DRAWERS. CÓMODA



STOCKHOLM CUPBOARD. ALACENA



STOCKHOLM BEDSIDE. MESITA DE NOCHE



STOCKHOLM DESK. ESCRITORIO



STOCKHOLM

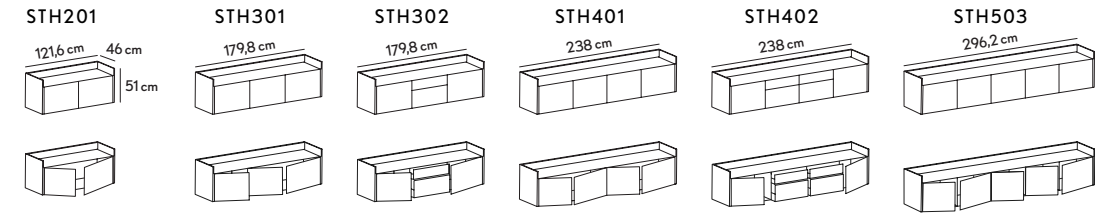

STOCKHOLM TECHNIC

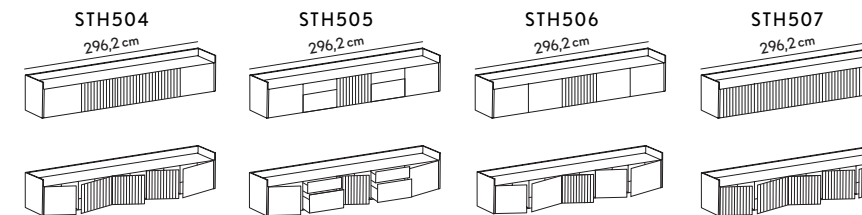
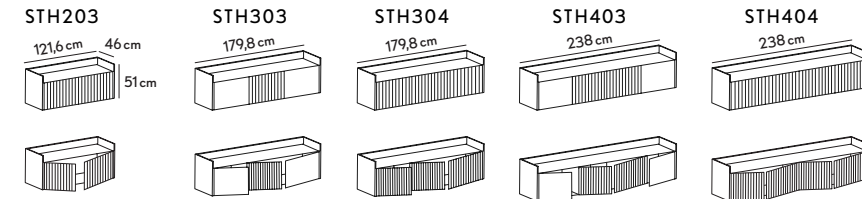

STOCKHOLM SLIM

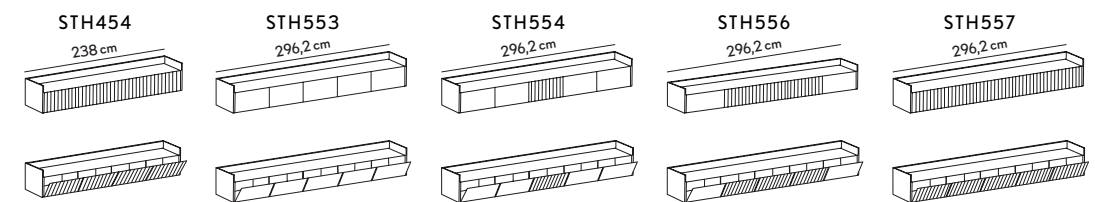
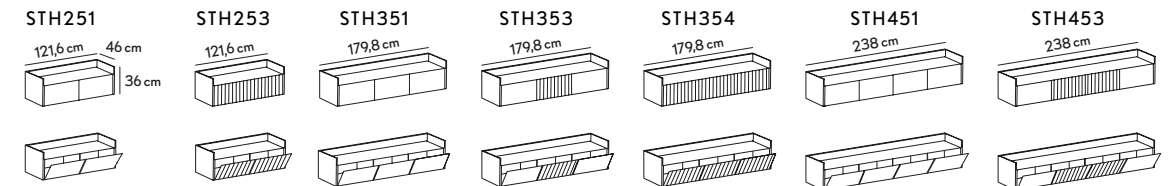

STOCKHOLM BEDSIDE. MESITA DE NOCHE

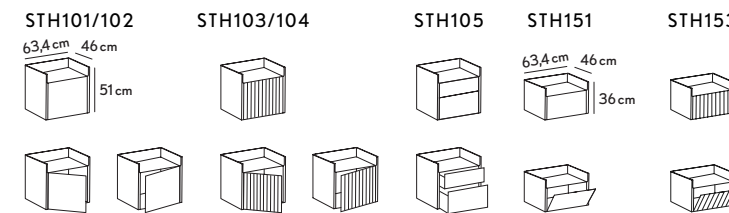

STOCKHOLM DESK. ESCRITORIO

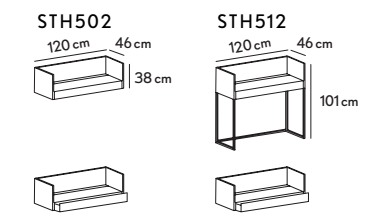

STOCKHOLM CUPBOARD. ALACENA

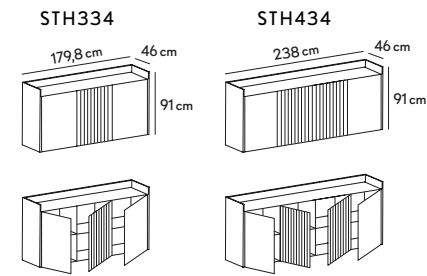
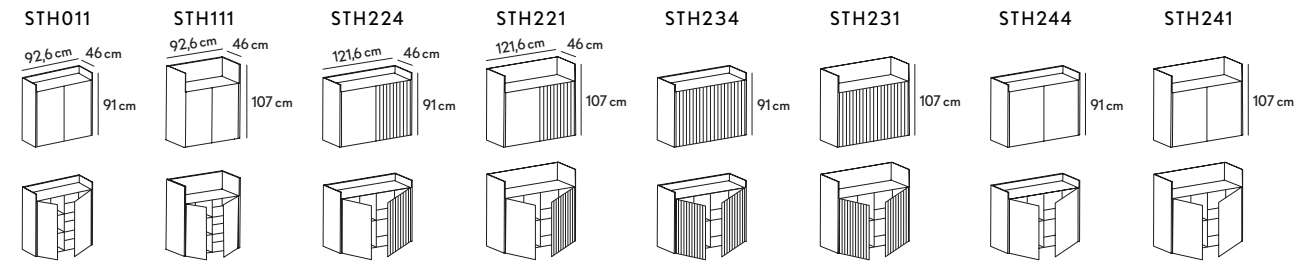

STOCKHOLM CHEST OF DRAWERS. CÓMODA

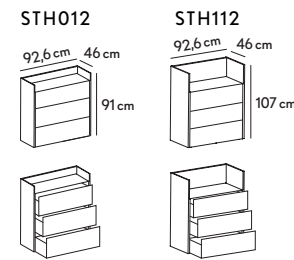

FINISHES. ACABADOS

UNITS. MÓDULOS



TOP. TAPA SUPERIOR



METAL BASE. ZÓCALOS

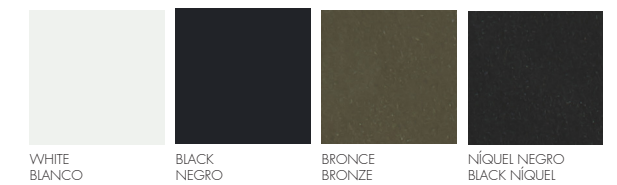

METAL BASE. ZÓCALO

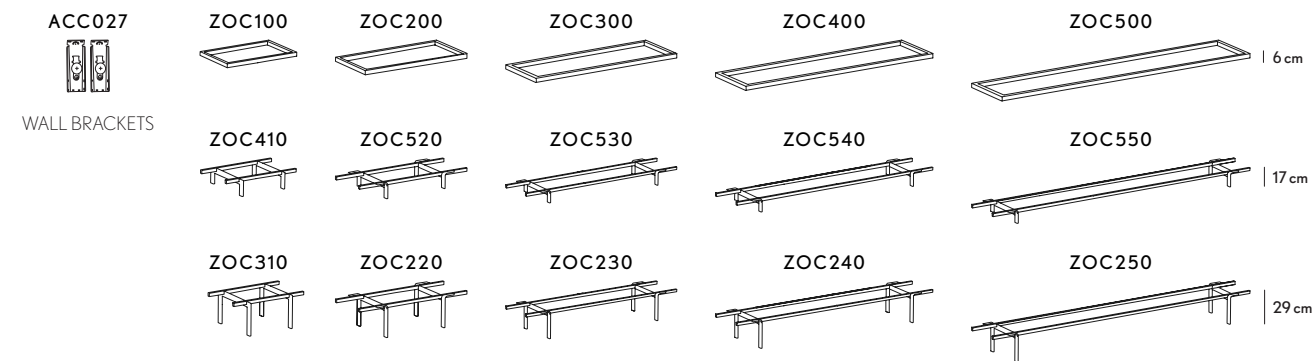

INTERIOR MEASURES. MEDIDAS INTERIORES

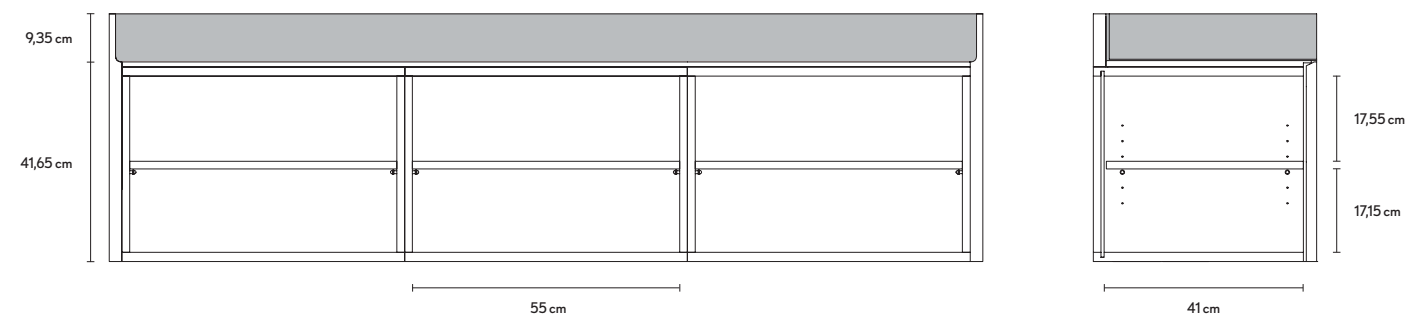

Fittings for Stockholm. Herrajes para Stockholm.



Fittings for Stockholm slim. Herrajes para Stockholm slim.

EXTRAS



All the slatted door modules of the Stockholm sideboard include the hinged flap and the machined cable management in the back. Do let us know if you do not need the cable management. Todos los aparadores con módulos alistonados, llevan accesorio pasacables tanto en la tapa como en la trasera. Si usted no quiere pasacables, comuníquelo.



Stockholm sideboard trimming back panel. Trasera embellecedora aparador Stockholm.

STOCKHOLM



Customizable length over 3 meters. Composiciones superiores a 3 metros.