

**viccarbe**

# Step Sofa

---

Designed by Vincent Van Duysen

Catalogue - EN

2013



## Vincent Van Duysen

Vincent Van Duysen was born in Lokeren, Belgium, in 1962, and undertook a degree in Architecture at the Higher Institute of Architecture Sint-Lucas, Ghent. Between 1986 and 1987 Van Duysen worked in Milan collaborating with Aldo Cibic - Sottsass Associati, after which, in 1990, he opened his studio in Antwerp specializing in architecture and interiors.

A strong relationship exists between Van Duysen's designs and his architectural projects - he chooses to develop furniture and objects from an architectural perspective - creating spatial relations rather than shapes. A rescaled interpretation of his architectural work, Van Duysen creates pieces that provide a sense of purity and essentialism, yet remaining tactile and grounded.

# Step — Sofa



Designed by Vincent van Duysen, 2013

Exquisite proportions, infinite compositions, and surprising comfort define Step, a modular sofa designed by the renowned architect Vincent Van Duysen. Handcrafted seams give warmth to this unique collection which is pure functionality and adaptability. Conceived in 2013, Step is the result of a deep analysis of monolithic forms related to the cubist style movement. Cubist elements play a prominent role in the concept, and through its rationalization, a clean design is established and the strong

contours are enhanced by its distinctive stitching detail. Step is composed of a large island of modular elements, available in a variety of colors that offer the possibility to create countless compositions to fit in any space.

Finding the balance between durability and comfort, the Step collection was born as a modular system with which the user could compose and create his own sofa based on Van Duysen's various proposals.

On these pages, a picture of Step sofa with Giro low table



Project on the left: Private residence  
Interior design: Katherine Newman Design  
Pictures: Virginia Macdonald

Project on the right: Mirasal residence  
Arquitectura e interiores: Balzar Arquitectos  
Pictures: Mariela Apolonio



On these pages, a picture of Step sofa and a details of decorative seam made by hand







Project: The Ovolo Woolloomollo Hotel  
Interior design: HASSELL  
Pictures: Nicole England

Project: Amber Terminal  
Design: NEFA Architects  
Photography: Ilya Ivanov







Project: Generali Offices  
Project: mpeengineering, Agencia \_ Entis  
Pictures: Lea Anouchinsky



Project: Takasaki Theater.  
Pictures: Nacása & Partners Inc.  
Special thanks: Interiors Inc.





# Step Sofa

Technical Info - EN

STEP SOFA - COMPONENTS

**ST70**  
module 70 | 27 5/16"

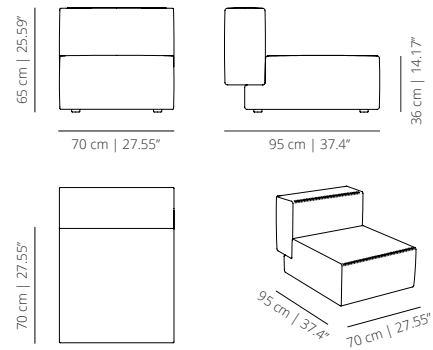

**ST90**  
module 90 | 35 7/16"

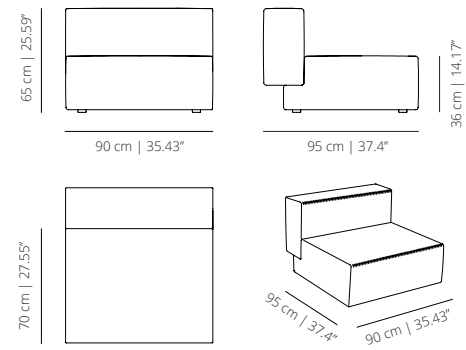

STEP SOFA - COMPONENTS

**STTA**  
wide arm

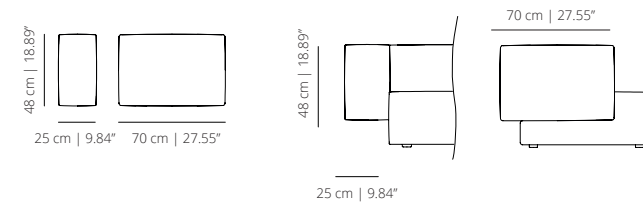

**STCH**  
chaise

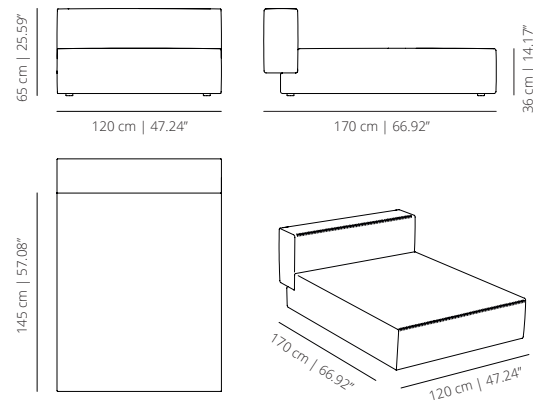

**STRI**  
corner

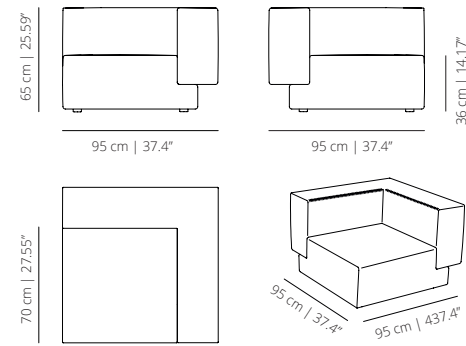

STEP SOFA - COMPOSITIONS

**COMPOSITION 1**  
sofa

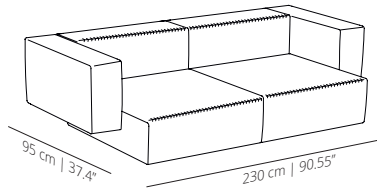

**COMPOSITION 2**  
sofa

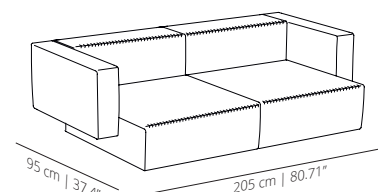

**STPO**  
pouf

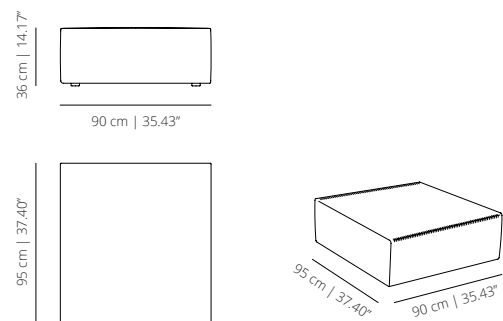

**STWA**  
narrow arm

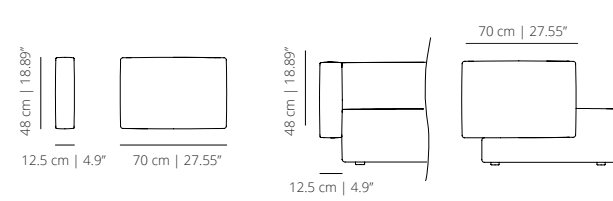

**COMPOSITION 3**  
sofa

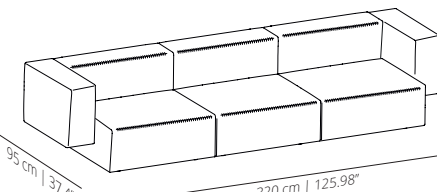

**COMPOSITION 4**  
sofa

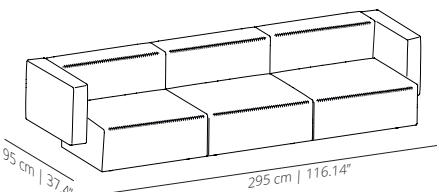

STEP SOFA - COMPOSITIONS

COMPOSITION 5  
sofa

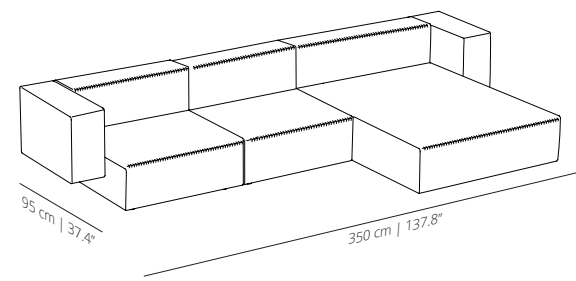

COMPOSITION 6  
sofa

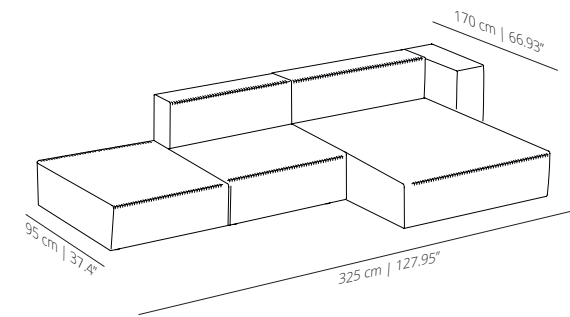

COMPOSITION 7  
sofa

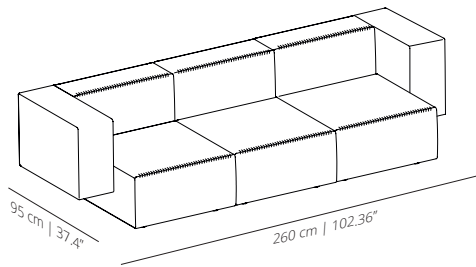

COMPOSITION 8  
sofa

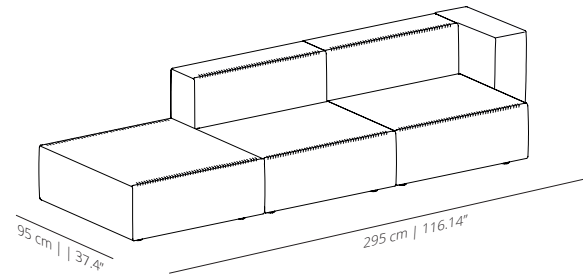

COMPOSITION 9  
sofa

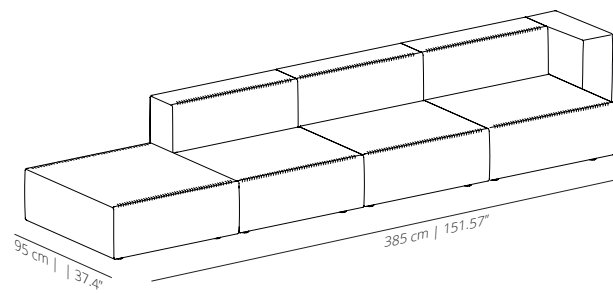

COMPOSITION 10  
sofa

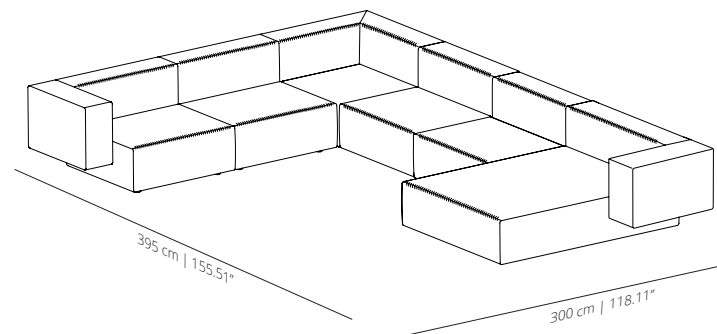

CUSHIONS

STEAL30  
cushion 60x30

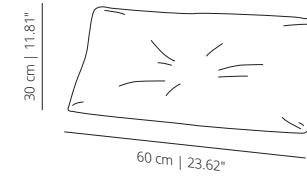

STEEL50  
cushion 50x50

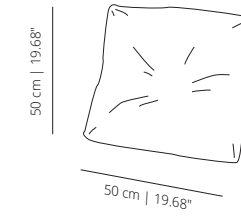

## FINISHES

---

### Upholstery

Check upholstery samples.

### SEAM\*

---



white



cream



sky blue



light grey



dark grey



green



red



deep blue



caramel



wine



black



*\*Decorative seams are made by hand.*

## TECHNICAL INFO

---

Interior structure of arms, back and seat in solid wood. We use PEFC certified wood. Woven seat and back structure. Expanded polyurethane foam in different densities. Polyester fibre covering. Fabric. Height equalising legs.

Not produced in leather.

**Seam** – colours available: white, black, red, sky blue, light grey, dark grey, green, cream, deep blue, caramel and wine.

**Cushions** – soft virgin fibre with anti-acarus treatment.

## CERTIFICATIONS

---

ANSI/BIFMA X5.4-2012 and UNE EN 16139:2013